

Z8 SERIES

Hydraulic performance table at 50 Hz

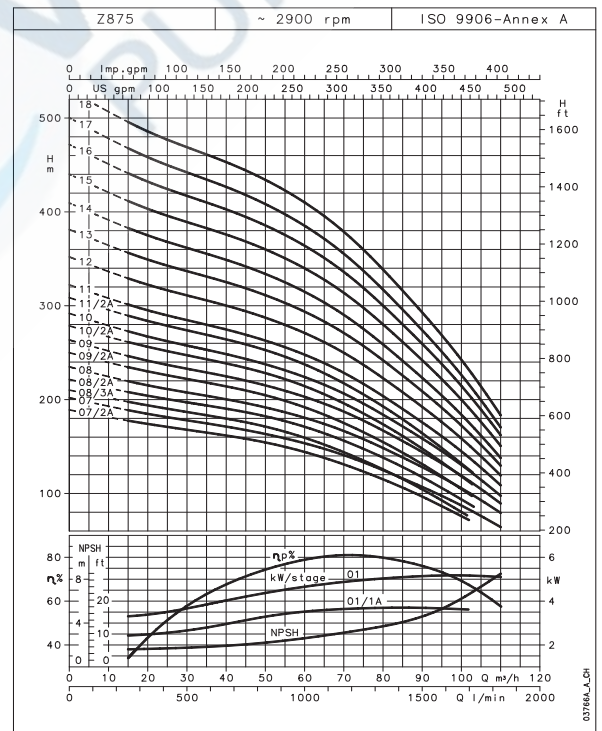
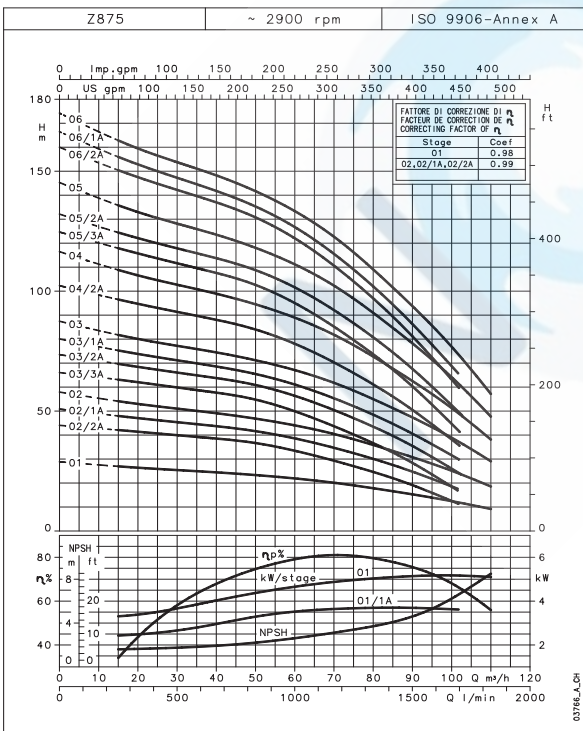
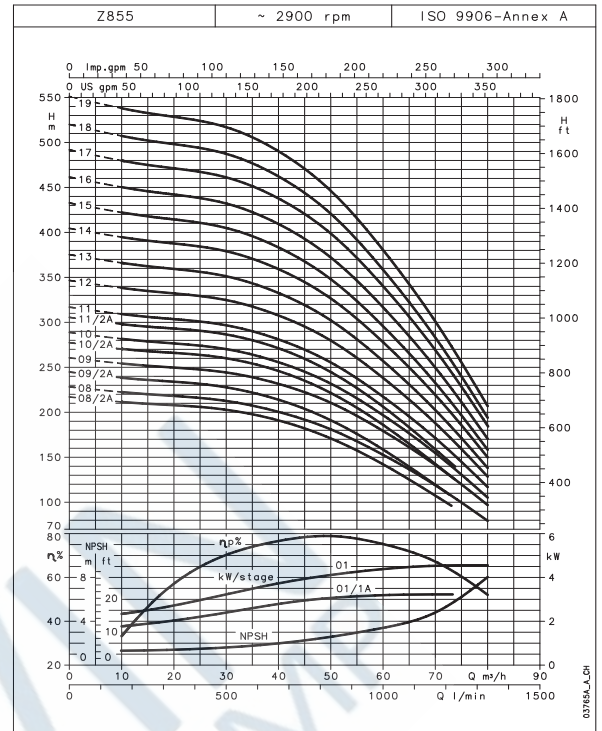
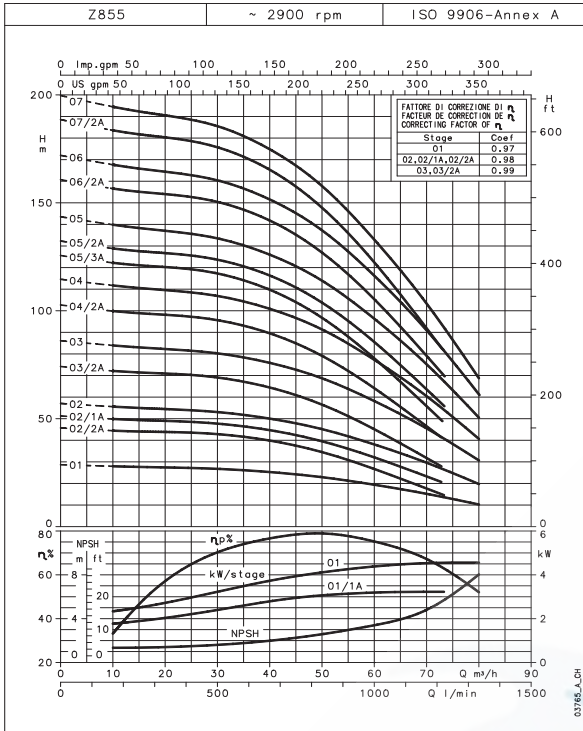

These performances are valid for liquids with density $\rho = 1.0 \text{ kg/dm}^3$ and kinematic viscosity $\nu = 1 \text{ mm}^2/\text{s}$.

Z8 SERIES

Hydraulic performance table at 50 Hz

4

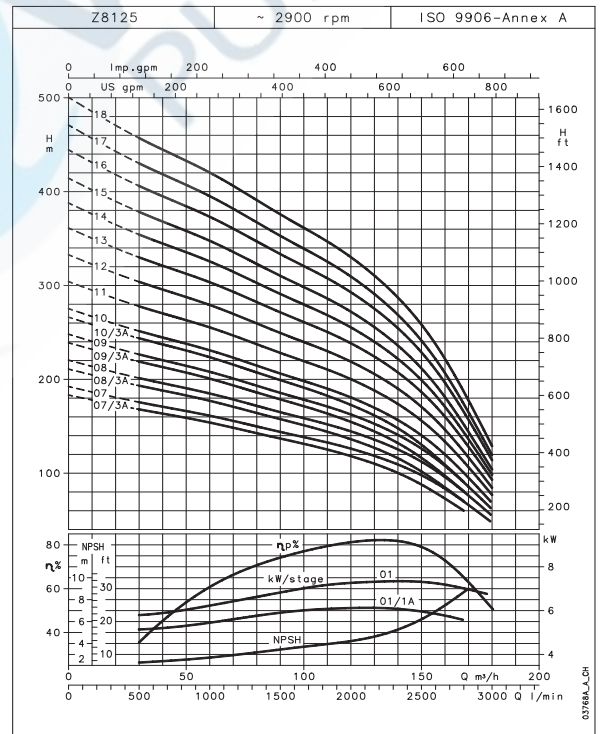
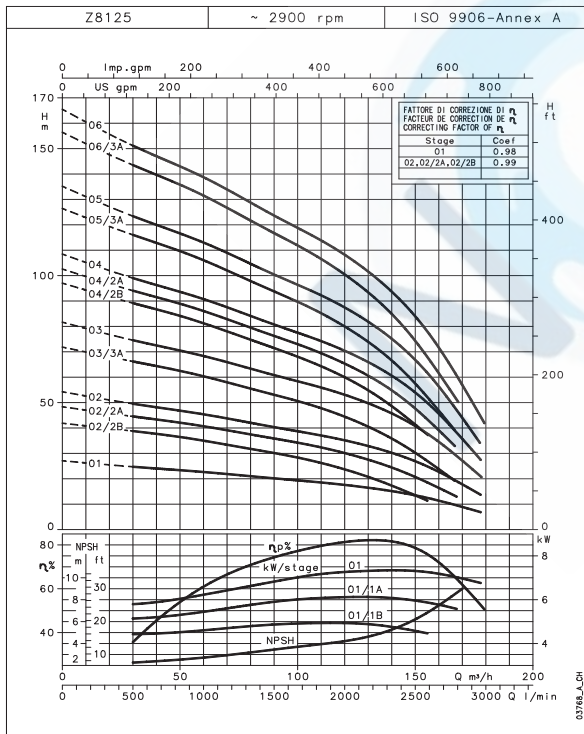
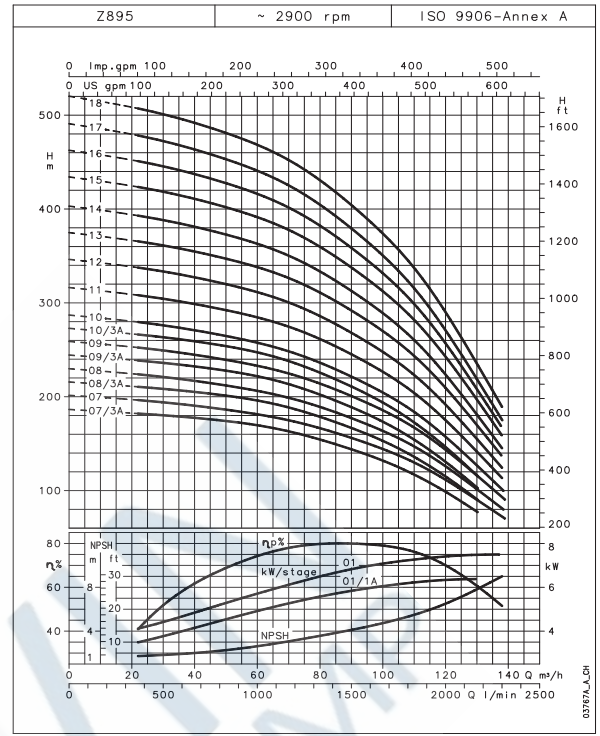
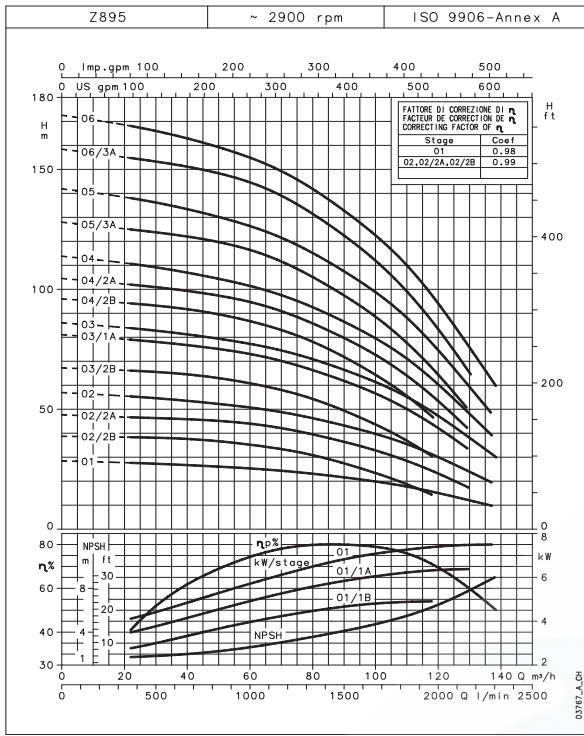

These performances are valid for liquids with density $\rho = 1.0 \text{ kg/dm}^3$ and kinematic viscosity $\nu = 1 \text{ mm}^2/\text{s}$.

Z855 SERIES, 1 TO 7 STAGES

Dimensions and weights

ELECTRO PUMP TYPE	DIMENSIONS (mm)				ELECTRO PUMP WEIGHT kg ⁽³⁾
	A ⁽⁴⁾	C ⁽¹⁾	M	Tmin ⁽²⁾	
Z855 01-L6W	1173	200	144	1613	68,6
Z855 02/2A-L6W	1348	200	144	1653	81,2
Z855 02/1A-L6W	1348	200	144	1653	81,2
Z855 02-L6W	1378	200	144	1683	85,2
Z855 03/2A-L6W	1553	200	144	1723	97,9
Z855 03-L6W	1663	200	144	1833	109,9
Z855 04/2A-L6W	1798	200	144	1833	118,5
Z855 04-L6W	1868	200	144	1903	126,5
Z855 05/3A-L6W	2003	200	144	1903	135,2
Z855 05/2A-L6W	2043	200	144	1943	138,2
Z855 05-L6W	2043	200	144	1943	138,2
Z855 06/2A-L6W	2306	200	144	2071	155,8
Z855 06-L6W	2386	200	144	2151	163,8
Z855 07/2A-L6W	2521	200	144	2151	172,5
Z855 07-L6W	2521	200	144	2151	172,5

z855-2p50-en_b_td

Z855 SERIES, 8 TO 19 STAGES

Dimensions and weights

ELECTRO PUMP TYPE	DIMENSIONS (mm)				ELECTRO PUMP WEIGHT kg ⁽³⁾
	A ⁽⁴⁾	C ⁽¹⁾	M	Tmin ⁽²⁾	
Z855 08/2A-L6W	2806	200	144	2301	195,1
Z855 08-L6W	2806	200	144	2301	195,1
Z855 09/2A-L6W	2941	200	144	2301	203,8
Z855 09-L8W	2835	203,3	192	2195	275,1
Z855 10/2A-L8W	2970	203,3	192	2195	283,8
Z855 10-L8W	2970	203,3	192	2195	283,8
Z855 11/2A-L8W	3105	203,3	192	2195	292,4
Z855 11-L8W	3195	203,3	192	2285	312,4
Z855 12-L8W	3330	203,3	192	2285	321,1
Z855 13-L8W	3370	203,3	192	2325	335,7
Z855 14-L8W	3780	203,3	192	2465	373,4
Z855 15-L8W	3915	203,3	192	2465	382
Z855 16-L8W	4140	203,3	192	2555	407,7
Z855 17-L8W	4275	203,3	192	2555	416,3
Z855 18-L8W	4470	203,3	192	2615	438
Z855 19-L8W	4725	203,3	192	2755	471,6

z855a-2p50-en_b_td

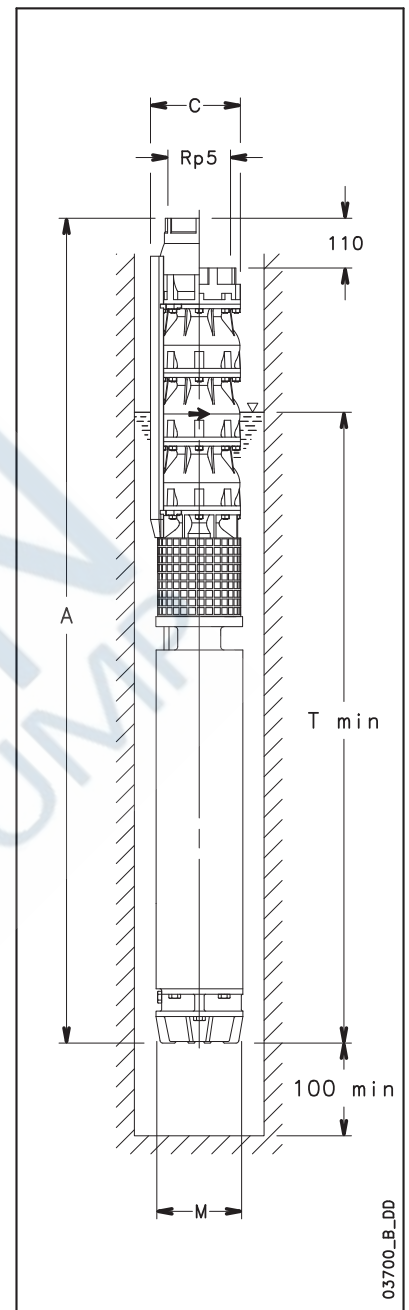

1) Max electric pump diameter with 2 motor cables included.

In case of 1 motor cable C = 198 mm with L6W motor.
C = 201,5 mm with L8W motor.

2) Tmin valid only for max flow speed of 4,2 m/s.

For higher speeds please contact our sales network.

3) Without cables.

4) For pumps without non-return valve, reduce dimension A by 110 mm, and reduce weight by 4 Kg.

Z875 SERIES, 1 TO 6 STAGES

Dimensions and weights

ELECTRO PUMP TYPE	DIMENSIONS (mm)				ELECTRO PUMP WEIGHT kg ⁽³⁾
	A ⁽⁴⁾	C ⁽¹⁾	M	Tmin ⁽²⁾	
Z875 01-L6W	1190	200	144	1613	68,9
Z875 02/2A-L6W	1382	200	144	1653	82,2
Z875 02/1A-L6W	1412	200	144	1683	86,2
Z875 02-L6W	1452	200	144	1723	90,2
Z875 03/3A-L6W	1604	200	144	1723	99,4
Z875 03/2A-L6W	1644	200	144	1763	103,4
Z875 03/1A-L6W	1714	200	144	1833	111,4
Z875 03-L6W	1784	200	144	1903	119,4
Z875 04/2A-L6W	1936	200	144	1903	128,6
Z875 04-L6W	1976	200	144	1943	131,6
Z875 05/3A-L6W	2128	200	144	1943	140,9
Z875 05/2A-L6W	2256	200	144	2071	149,9
Z875 05-L6W	2336	200	144	2151	157,9
Z875 06/2A-L6W	2488	200	144	2151	167,1
Z875 06/1A-L6W	2488	200	144	2151	167,1
Z875 06-L6W	2638	200	144	2301	181,1

z875-2p50-en_b_td

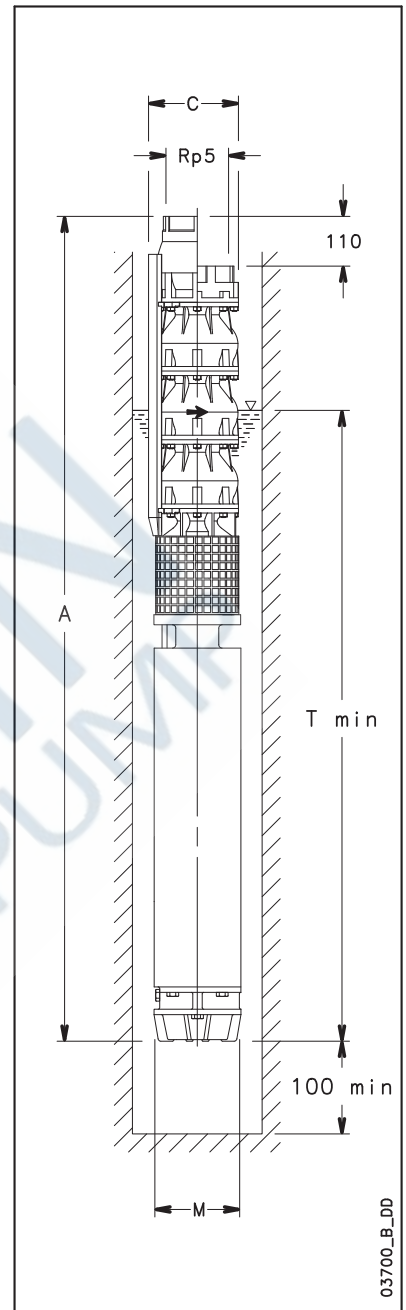

03700_B_DD

Z875 SERIES, 7 TO 18 STAGES

Dimensions and weights

ELECTRO PUMP TYPE	DIMENSIONS (mm)				ELECTRO PUMP WEIGHT kg ⁽³⁾
	A ⁽⁴⁾	C ⁽¹⁾	M	Tmin ⁽²⁾	
Z875 07/2A-L6W	2790	200	144	2301	190,3
Z875 07-L6W	2790	200	144	2301	190,3
Z875 08/3A-L6W	2942	200	144	2301	199,5
Z875 08/2A-L8W	2746	203,3	192	2105	252,9
Z875 08-L8W	2836	203,3	192	2195	270,9
Z875 09/2A-L8W	2988	203,3	192	2195	280,1
Z875 09-L8W	3078	203,3	192	2285	300,1
Z875 10/2A-L8W	3230	203,3	192	2285	309,4
Z875 10-L8W	3230	203,3	192	2285	309,4
Z875 11/2A-L8W	3382	203,3	192	2285	318,6
Z875 11-L8W	3422	203,3	192	2325	324,6
Z875 12-L8W	3714	203,3	192	2465	362,8
Z875 13-L8W	3875	203,3	192	2465	372
Z875 14-L8W	4108	203,3	192	2555	398,3
Z875 15-L8W	4260	203,3	192	2555	407,5
Z875 16-L8W	4472	203,3	192	2615	429,7
Z875 17-L8W	4764	203,3	192	2755	464
Z875 18-L8W	4937	203,3	192	2755	473,2

z875a-2p50-en_b_td

- 1) Max electric pump diameter with 2 motor cables included.
In case of 1 motor cable C = 198 mm with L6W motor.
C = 201,5 mm with L8W motor.
- 2) Tmin valid only for max flow speed of 4,2 m/s.
For higher speeds please contact our sales network.
- 3) Without cables.
- 4) For pumps without non-return valve, reduce dimension A by 110 mm, and reduce weight by 4 Kg.

Z895 SERIES, 1 TO 6 STAGES

Dimensions and weights

ELECTRO PUMP TYPE	DIMENSIONS (mm)				ELECTRO PUMP TYPE kg ⁽³⁾
	A ⁽⁴⁾	C ⁽¹⁾	M	T _{min} ⁽²⁾	
Z895 01-L6W	1230	200	144	1653	72,9
Z895 02/2B-L6W	1452	200	144	1723	90,2
Z895 02/2A-L6W	1492	200	144	1763	94,2
Z895 02-L6W	1562	200	144	1833	102,2
Z895 03/2B-L6W	1784	200	144	1903	119,4
Z895 03/1A-L6W	1824	200	144	1943	122,4
Z895 03-L6W	1952	200	144	2071	131,4
Z895 04/2B-L6W	2104	200	144	2071	140,6
Z895 04/2A-L6W	2184	200	144	2151	148,6
Z895 04-L6W	2184	200	144	2151	148,6
Z895 05/3A-L6W	2486	200	144	2301	171,9
Z895 05-L6W	2486	200	144	2301	171,9
Z895 06/3A-L8W	2532	203,3	192	2195	253,1
Z895 06-L8W	2532	203,3	192	2195	253,1

z895-2p50-en_b_td

Z895 SERIES, 7 TO 18 STAGES

Dimensions and weights

ELECTRO PUMP TYPE	DIMENSIONS (mm)				ELECTRO PUMP TYPE kg ⁽³⁾
	A ⁽⁴⁾	C ⁽¹⁾	M	T _{min} ⁽²⁾	
Z895 07/3A-L8W	2774	203,3	192	2285	281,7
Z895 07-L8W	2774	203,3	192	2285	281,7
Z895 08/3A-L8W	2966	203,3	192	2325	296,9
Z895 08-L8W	3016	203,3	192	2375	307,9
Z895 09/3A-L8W	3258	203,3	192	2465	335,1
Z895 09-L8W	3258	203,3	192	2465	335,1
Z895 10/3A-L8W	3500	203,3	192	2555	361,4
Z895 10-L8W	3500	203,3	192	2555	361,4
Z895 11-L8W	3712	203,3	192	2615	383,6
Z895 12-L8W	3864	203,3	192	2615	392,8
Z895 13-L10W	4124	236	236	2702	538
Z895 14-L10W	4276	236	236	2702	547,3
Z895 15-L10W	4578	236	236	2852	603,5
Z895 16-L10W	4730	236	236	2852	612,7
Z895 17-L10W	4882	236	236	2852	622
Z895 18-L10W	5164	236	236	2982	670,2

z895a-2p50-en_b_td

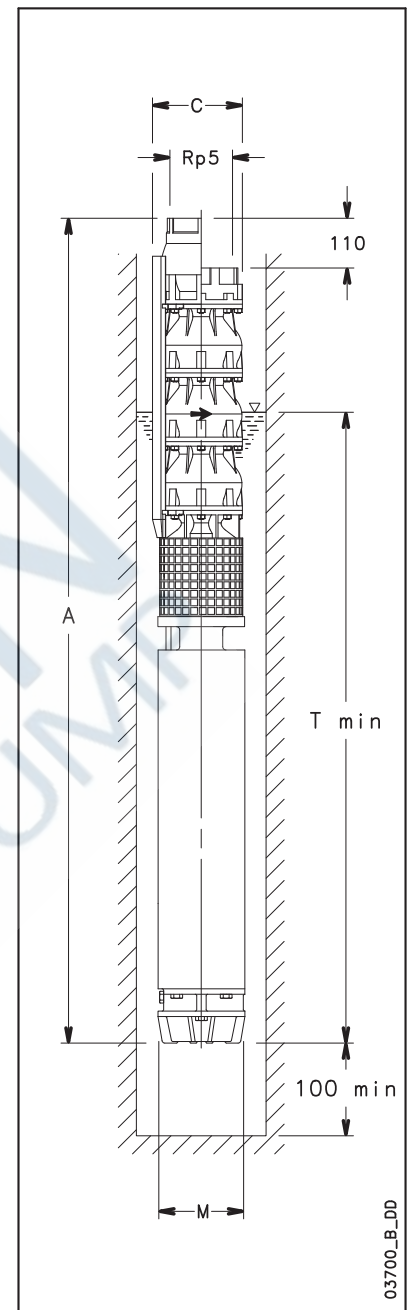

4

1) Max electric pump diameter with 2 motor cables included.

In case of 1 motor cable C = 198 mm with L6W motor.
C = 201,5 mm with L8W motor.

2) T min valid only for max flow speed of 4,2 m/s.

For higher speeds please contact our sales network.

3) Without cables.

4) For pumps without non-return valve, reduce dimension A by 110 mm, and reduce weight by 4 Kg.

Z8125 SERIES, 1 TO 6 STAGES

Dimensions and weights

ELECTRO PUMP TYPE	DIMENSIONS (mm)				ELECTRO PUMP WEIGHT kg ⁽³⁾
	A ⁽⁴⁾	C ⁽¹⁾	M	Tmin ⁽²⁾	
Z8125 01-L6W	1230	200	144	1653	72,9
Z8125 02/2B-L6W	1452	200	144	1723	90,2
Z8125 02/2A-L6W	1492	200	144	1763	94,2
Z8125 02-L6W	1562	200	144	1833	102,2
Z8125 03/3A-L6W	1784	200	144	1903	119,4
Z8125 03-L6W	1824	200	144	1943	122,4
Z8125 04/2B-L6W	2104	200	144	2071	140,6
Z8125 04/2A-L6W	2184	200	144	2151	148,6
Z8125 04-L6W	2184	200	144	2151	148,6
Z8125 05/3A-L6W	2486	200	144	2301	171,9
Z8125 05-L6W	2486	200	144	2301	171,9
Z8125 06/3A-L8W	2532	203,3	192	2195	253,1
Z8125 06-L8W	2532	203,3	192	2195	253,1

z8125-2p50-en_b_td

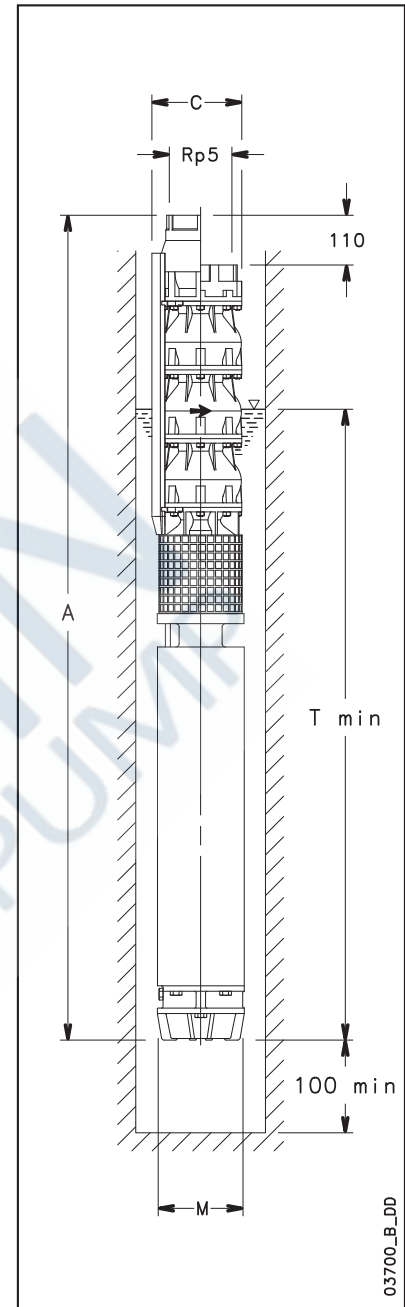

03700_B_DD

Z8125 SERIES, 7 TO 18 STAGES

Dimensions and weights

ELECTRO PUMP TYPE	DIMENSIONS (mm)				ELECTRO PUMP WEIGHT kg ⁽³⁾
	A ⁽⁴⁾	C ⁽¹⁾	M	Tmin ⁽²⁾	
Z8125 07/3A-L8W	2774	203,3	192	2285	281,7
Z8125 07-L8W	2774	203,3	192	2285	81,72
Z8125 08/3A-L8W	2966	203,3	192	2325	296,9
Z8125 08-L8W	3016	203,3	192	2375	307,9
Z8125 09/3A-L8W	3258	203,3	192	2465	335,1
Z8125 09-L8W	3258	203,3	192	2465	335,1
Z8125 10/3A-L8W	3500	203,3	192	2555	361,4
Z8125 10-L8W	3500	203,3	192	2555	361,4
Z8125 11-L8W	3712	203,3	192	2615	383,6
Z8125 12-L8W	4004	203,3	192	2755	417,8
Z8125 13-L8W	4156	203,3	192	2755	427
Z8125 14-L10W	4276	236	236	2702	547,3
Z8125 15-L10W	4428	236	236	2702	556,5
Z8125 16-L10W	4730	236	236	2852	612,7
Z8125 17-L10W	4882	236	236	2852	622
Z8125 18-L10W	5164	236	236	2982	670,2

z8125a-2p50-en_b_td

- 1) Max electric pump diameter with 2 motor cables included.
In case of 1 motor cable C = 201,5 mm with L8W motor.
C = 236 mm with L10W motor.
- 2) Tmin valid only for max flow speed of 4,2 m/s.
For higher speeds please contact our sales network.
- 3) Without cables.
- 4) For pumps without non-return valve, reduce dimension A by 110 mm, and reduce weight by 4 Kg.

Z855 PUMP SERIES

Dimensions and weights

PUMP TYPE	MAX POWER ABSORBED BY PUMP at 2900 rpm kW	DIMENSIONS (mm)			WEIGHT kg ⁽³⁾
		L ⁽³⁾	I	U _{min} ⁽²⁾	
Z855 01	4,6	325	235	1000	26,6
Z855 02/2A	6,4	460	235	1000	35,2
Z855 02/1A	7,7	460	235	1000	35,2
Z855 02	9,0	460	235	1000	35,2
Z855 03/2A	10,8	595	235	1000	43,9
Z855 03	13,3	595	235	1000	43,9
Z855 04/2A	15,1	730	235	1000	52,5
Z855 04	17,6	730	235	1000	52,5
Z855 05/3A	18,3	865	235	1000	61,2
Z855 05/2A	20,8	865	235	1000	61,2
Z855 05	22,0	865	235	1000	61,2
Z855 06/2A	23,9	1000	235	1000	69,8
Z855 06	26,4	1000	235	1000	69,8
Z855 07/2A	28,3	1135	235	1000	78,5
Z855 07	30,8	1135	235	1000	78,5
Z855 08/2A	32,7	1270	235	1000	87,1
Z855 08	35,2	1270	235	1000	87,1
Z855 09/2A	37,1	1405	235	1000	95,8
Z855 09	39,6	1405	235	1000	95,1
Z855 10/2A	41,5	1540	235	1000	103,8
Z855 10	44,0	1540	235	1000	103,8
Z855 11/2A	45,9	1675	235	1000	112,4
Z855 11	48,4	1675	235	1000	112,4
Z855 12	52,8	1810	235	1000	121,1
Z855 13	57,2	1945	235	1000	129,7
Z855 14	61,6	2080	235	1000	138,4
Z855 15	66,0	2215	235	1000	147
Z855 16	70,4	2350	235	1000	155,7
Z855 17	74,8	2485	235	1000	164,3
Z855 18	79,2	2620	235	1000	173
Z855 19	83,6	2755	235	1000	181,6

z855p-2p50-en_a_td

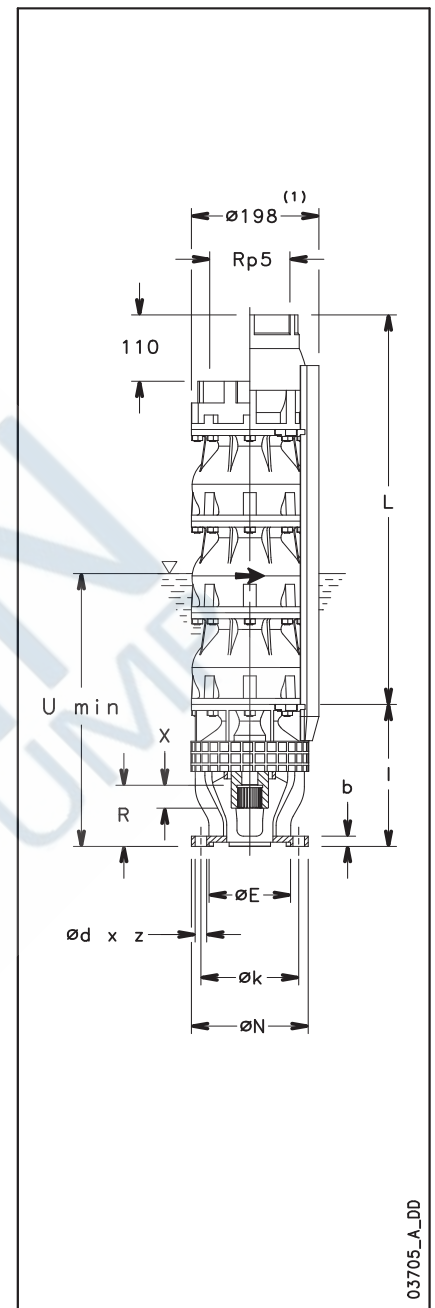

4

Motor coupling

MOTOR	DIMENSIONS (mm)							
	N	k	d	z	b	E ^{H7}	R	X
6" (NEMA)	182	111	13,5	4	17	76,16	73	24
8" (NEMA)	182	152,4	18	4	17	127	101,3	40

6" and 8" coupling according to NEMA standards

z8-mtcn-2p50-en_a_td

03705_A_DD

- 1) Max pump diameter with 2 motor cable included.
- 2) U min valid only for max flow speed of 4,2 m/s.
For higher speeds please contact our sales network.
- 3) For pumps without non-return valve, reduce dimension L by 110 mm, and reduce weight by 4 Kg.

Z875 PUMP SERIES

Dimensions and weights

4

PUMP TYPE	MAX POWER ABSORBED BY PUMP at 2900 min ⁻¹ kW	DIMENSIONS (mm)			WEIGHT kg ⁽³⁾
		L ⁽³⁾	l	Umin ⁽²⁾	
Z875 01	5,3	342	235	1000	26,9
Z875 02/2A	7,6	494	235	1000	36,2
Z875 02/1A	9,0	494	235	1000	36,2
Z875 02	10,5	494	235	1000	36,2
Z875 03/3A	11,3	646	235	1000	45,4
Z875 03/2A	12,7	646	235	1000	45,4
Z875 03/1A	14,2	646	235	1000	45,4
Z875 03	15,6	646	235	1000	45,4
Z875 04/2A	17,7	798	235	1000	54,6
Z875 04	20,6	798	235	1000	54,6
Z875 05/3A	21,5	950	235	1000	63,9
Z875 05/2A	22,9	950	235	1000	63,9
Z875 05	25,8	950	235	1000	63,9
Z875 06/2A	28,0	1102	235	1000	73,1
Z875 06/1A	29,5	1102	235	1000	73,1
Z875 06	30,9	1102	235	1000	73,1
Z875 07/2A	33,2	1254	235	1000	82,3
Z875 07	36,1	1254	235	1000	82,3
Z875 08/3A	36,9	1406	235	1000	91,5
Z875 08/2A	38,3	1406	235	1000	90,9
Z875 08	41,2	1406	235	1000	90,9
Z875 09/2A	43,5	1558	235	1000	100,1
Z875 9	46,4	1558	235	1000	100,1
Z875 10/2A	48,6	1710	235	1000	109,4
Z875 10	51,5	1710	235	1000	109,4
Z875 11/2A	53,8	1862	235	1000	118,6
Z875 11	56,7	1862	235	1000	118,6
Z875 12	61,8	2014	235	1000	127,8
Z875 13	67,0	2166	235	1000	137
Z875 14	72,1	2318	235	1000	146,3
Z875 15	77,3	2470	235	1000	155,5
Z875 16	82,4	2622	235	1000	164,7
Z875 17	87,6	2774	235	1000	174
Z875 18	92,7	2926	256	1000	183,2

z875p-2p50-en_a_td

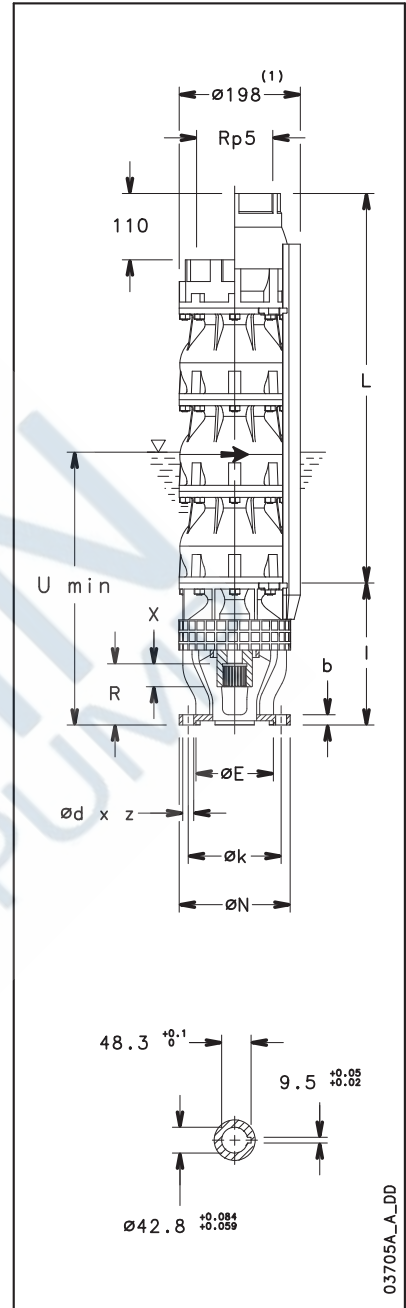

Motor coupling

MOTOR	DIMENSIONS (mm)							
	N	k	d	z	b	E ^{H7}	R	X
6" (NEMA)	182	111	13,5	4	17	76,16	73	24
8" (NEMA)	182	152,4	18	4	17	127	101,3	40
10"	232	190,5	M16	4	21	127	101,3	84

6" and 8" coupling according to NEMA standards

z8a-mtcn-2p50-en_a_td

1) Max pump diameter with 2 motor cable included.

2) U min valid only for max flow speed of 4,2 m/s.

For higher speeds please contact our sales network.

3) For pumps without non-return valve, reduce dimension L by 110 mm, and reduce weight by 4 Kg.

Z875 PUMP SERIS

Dimensions and weights

PUMP TYPE	MAX POWER ABSORBED BY PUMP at 2900 rpm kW	DIMENSIONS (mm)			WEIGHT kg ⁽³⁾
		L ⁽³⁾	l	U _{min} ⁽²⁾	
Z895 01	7,7	342	235	1000	26,9
Z895 02/2B	10,0	494	235	1000	36,2
Z895 02/2A	12,8	494	235	1000	36,2
Z895 02	15,2	494	235	1000	36,2
Z895 03/2B	17,4	646	235	1000	45,4
Z895 03/1A	21,4	646	235	1000	45,4
Z895 03	22,5	646	235	1000	45,4
Z895 04/2B	24,6	798	235	1000	54,6
Z895 04/2A	27,4	798	235	1000	54,6
Z895 04	29,8	798	235	1000	54,6
Z895 05/3A	33,7	950	235	1000	63,9
Z895 05	37,2	950	235	1000	63,9
Z895 06/3A	41,1	1102	235	1000	73,1
Z895 06	44,6	1102	235	1000	73,1
Z895 07/3A	48,6	1254	235	1000	81,7
Z895 07	52,1	1254	235	1000	81,7
Z895 08/3A	56,0	1406	235	1000	90,9
Z895 08	59,5	1406	235	1000	90,9
Z895 09/3A	63,5	1558	235	1000	100,1
Z895 09	67,0	1558	235	1000	100,1
Z895 10/3A	70,9	1710	235	1000	109,4
Z895 10	74,4	1710	235	1000	109,4
Z895 11	81,8	1862	235	1000	118,6
Z895 12	89,3	2014	235	1000	127,8
Z895 13	96,7	2166	256	1000	137
Z895 14	104,2	2318	256	1000	146,3
Z895 15	111,6	2470	256	1000	155,5
Z895 16	119,0	2622	256	1000	164,7
Z895 17	126,5	2774	256	1000	174
Z895 18	133,9	2926	256	1000	183,2

z895p-2p50-en_a_td

Motor coupling

MOTOR	DIMENSIONS (mm)							
	N	k	d	z	b	E ^{H7}	R	X
6" (NEMA)	182	111	13,5	4	17	76,16	73	24
8" (NEMA)	182	152,4	18	4	17	127	101,3	40
10"	232	190,5	M16	4	21	127	101,3	84

6" and 8" coupling according to NEMA standards

z8a-mtcn-2p50-en_a_td

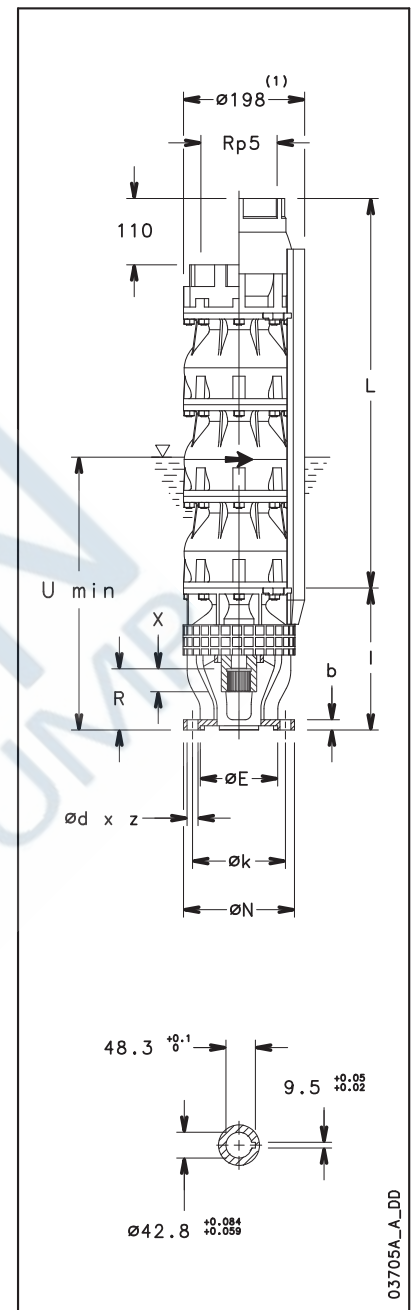

- 1) Max pump diameter with 2 motor cable included.
- 2) U min valid only for max flow speed of 4,2 m/s.
For higher speeds please contact our sales network.
- 3) For pumps without non-return valve, reduce dimension L by 110 mm, and reduce weight by 4 Kg.

Z8125 PUMP SERIES

Dimensions and weights

4

PUMP TYPE	MAX POWER ABSORBED BY PUMP at 2900 min ⁻¹ kW	DIMENSIONS (mm)			WEIGHT kg ⁽³⁾
		L ⁽³⁾	l	Umin ⁽²⁾	
Z8125 01	7,5	342	235	1000	26,9
Z8125 02/2B	10,0	494	235	1000	36,2
Z8125 02/2A	12,2	494	235	1000	36,2
Z8125 02	14,8	494	235	1000	36,2
Z8125 03/3A	18,1	646	235	1000	45,4
Z8125 03	22,0	646	235	1000	45,4
Z8125 04/2B	24,3	798	235	1000	54,6
Z8125 04/2A	26,5	798	235	1000	54,6
Z8125 04	29,0	798	235	1000	54,6
Z8125 05/3A	32,5	950	235	1000	63,9
Z8125 05	36,3	950	235	1000	63,9
Z8125 06/3A	39,7	1102	235	1000	73,1
Z8125 06	43,5	1102	235	1000	73,1
Z8125 07/3A	47,0	1254	235	1000	81,7
Z8125 07	50,8	1254	235	1000	81,7
Z8125 08/3A	54,2	1406	235	1000	90,9
Z8125 08	58,0	1406	235	1000	90,9
Z8125 09/3A	61,5	1558	235	1000	100,1
Z8125 09	65,3	1558	235	1000	100,1
Z8125 10/3A	68,7	1710	235	1000	109,4
Z8125 10	72,5	1710	235	1000	109,4
Z8125 11	79,8	1862	235	1000	118,6
Z8125 12	87,0	2014	235	1000	127,8
Z8125 13	94,3	2166	235	1000	137
Z8125 14	101,5	2318	256	1000	146,3
Z8125 15	108,8	2470	256	1000	155,5
Z8125 16	116,0	2622	256	1000	164,7
Z8125 17	123,3	2774	256	1000	174
Z8125 18	130,5	2926	256	1000	183,2

z8125p-2p50-en_b_td

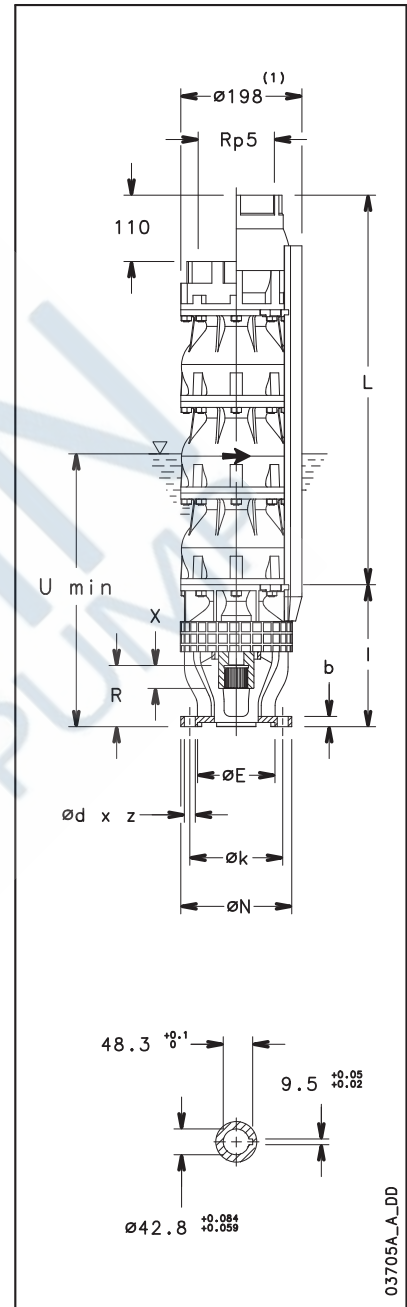

03705A_A_DD

Motor coupling

MOTOR	DIMENSIONS (mm)							
	N	k	d	z	b	E ^{H7}	R	X
6" (NEMA)	182	111	13,5	4	17	76,16	73	24
8" (NEMA)	182	152,4	18	4	17	127	101,3	40
10"	232	190,5	M16	4	21	127	101,3	84

6" and 8" coupling according to NEMA standards

z8a-mtcn-2p50-en_a_td

- 1) Max pump diameter with 2 motor cable included.
- 2) U min valid only for max flow speed of 4,2 m/s.
For higher speeds please contact our sales network.
- 3) For pumps without non-return valve, reduce dimension L by 110 mm, and reduce weight by 4 Kg.